

PROTECTOR™ server and network cabinets are a reliable way to keep sensitive electronics safe. The professional design features a ventilation rate of more than 74%, providing adequate cooling for the entire system. With integrated power and cable management; plus a full selection of accessories, Emcor's PROTECTOR server and network cabinets will make integrating your data center or data closet fast and easy.



Features

- Curved locking front door with ventilation rate above 80%
- Split “french style” locking rear door with ventilation rate above 80%
- Horizontally split locking side panels make access easy
- Two heights, two depths, and two widths available
- Rear vertical cable managers (two) included
- Square hole mounting rails are adjustable front to rear
- Grounding kit and baying hardware included
- Levelers and heavy duty casters come standard
- Full range of optional accessories
- 5 year warranty

Paint/Finish

Textured black powder

Static Load Rating

3000 lbs. [1364 kg.]

Dynamic Load Rating

2400 lbs. [1088 kg.]

Industry Standards

EIA 310-D



Adjustable Mounting Rails

Fully adjustable front to rear.
Numbers assist with alignment.
Square holes accept Rackstuds™



Lift Off Doors

Quick release. Easy on and off.
Field reversible. 140° of rotation.
Ground wire and locks included.

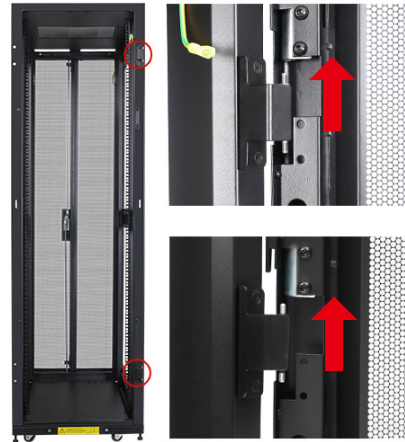

Integrated Cable Management

Vertical cable managers are included with every cabinet. Use the managers to route cables or mount power strips. In addition, the top and bottom panels include integrated cable entry/exit points.



600mm Wide

800mm Wide

Components

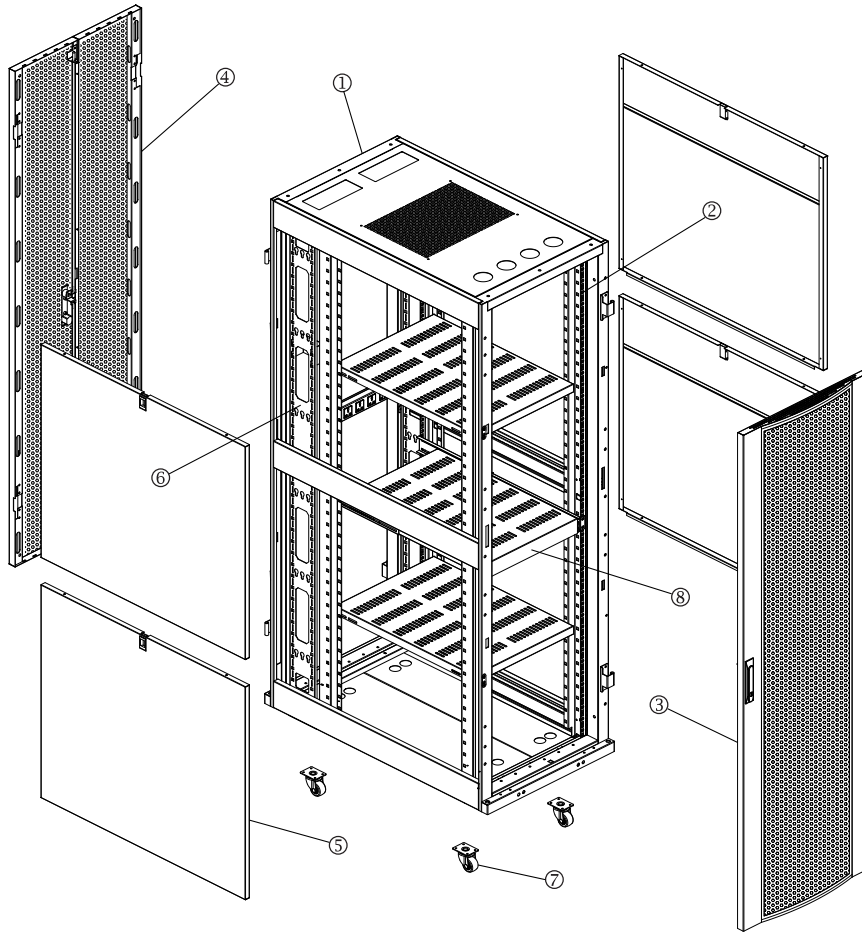

Components	
01	Frame
02	Mounting Rail
03	Front Door
04	Rear Panel
05	Side Panel
06	Vertical Cable Manager
07	Heavy Duty Caster
08	Shelf (optional)

Material	
Frame	12 Gauge
Mounting Rail	12 Gauge
Top/Bottom	12 Gauge
Front/Rear Door	14 Gauge
Side Panel	16 Gauge

PROTECTOR™ Server and Network Cabinets

Easy Ordering Part Numbers

Includes: Frame, 2 Pair Square Hole Rails, Solid Side Panels, Perforated Door on Front, Split Perforated "French Style" Door on Rear, Top with Cable Knockouts and Cooling Provisions, Bottom Panel, 2 Vertical Lacing Panels, Casters, and Levelers.

600mm Width Catalog Number	Overall Dimensions H x W x D in. [mm]	Rack Units
DC-42U2442-P	78.84" x 24.00" x 42.12" [2000 x 600 x 1070]	42U
DC-42U2448-P	78.84" x 24.00" x 47.25" [2000 x 600 x 1200]	42U
DC-47U2442-P	86.61" x 24.00" x 42.12" [2200 x 600 x 1070]	47U
DC-47U2448-P	86.61" x 24.00" x 47.25" [2200 x 600 x 1200]	47U

800mm Width* Catalog Number	Overall Dimensions H x W x D in. [mm]	Rack Units
DC-42U3242-P	78.84" x 31.50" x 42.12" [2000 x 800 x 1070]	42U
DC-42U3248-P	78.84" x 31.50" x 47.25" [2000 x 800 x 1200]	42U
DC-47U3242-P	86.61" x 31.50" x 42.12" [2200 x 800 x 1070]	47U
DC-47U3248-P	86.61" x 31.50" x 47.25" [2200 x 800 x 1200]	47U

*Rails centered in 800mm opening

Technical Specifications

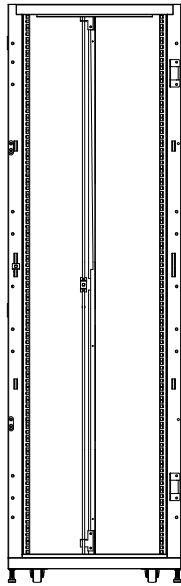

Front (w/o front door)

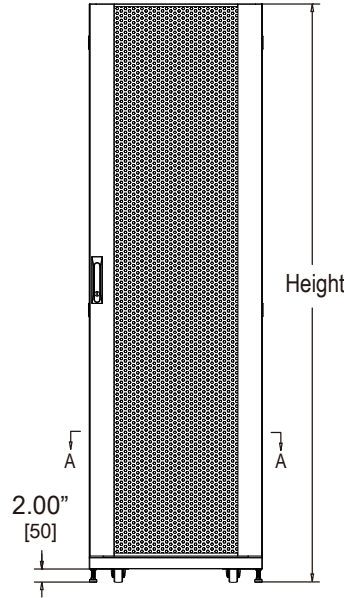

Front

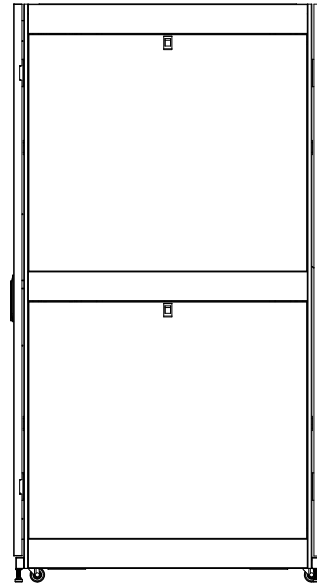

Side

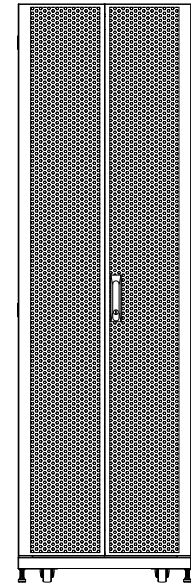

Back

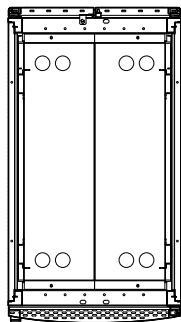

A-A Section

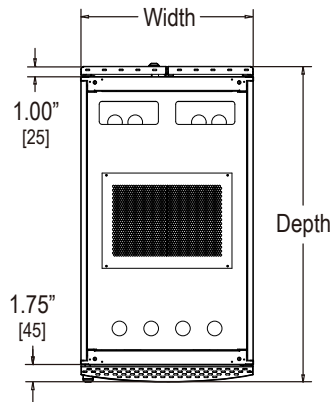

Top

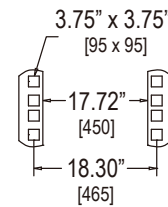

Mounting Dimension

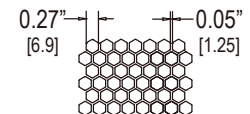

Scale 6:1