



# Emcor<sup>®</sup> Cabinets and Enclosures

[www.crenlo.com/emcor](http://www.crenlo.com/emcor) | 507-287-3535

ESQ<sup>®</sup>



G-Series<sup>®</sup>



10-Series<sup>®</sup>





### **Why Crenlo**

At a casual glance, many enclosures look pretty much alike. However, all enclosures are not created equal. A quality enclosure not only maintains a better appearance over time, it also does a better job of protecting the components within it; no matter what the external environment.

Crenlo ensures conformance to high quality manufacturing standards in all elements of the fabrication process. Manufacturing process controls are utilized from the moment raw material is received and continue through final product assembly and inspection. Dimensional accuracy is statistically audited and verified throughout the cycle with the aid of three state-of-the-art coordinated measuring machines. All products are produced under the internationally recognized ISO 9001 quality assurance program.



## Emcor® Enclosures

Select from three flexible enclosure product lines, each featuring an extensive selection of rack heights, widths, depths, and styles that target your specific design requirements. These cabinets support a mix of computer, data storage, network and security equipment. Use inside or outside the data center in smaller computer rooms or in premiere network applications. A variety of external and internal accessories are available to complete your design. Modified or custom designs are also available.

### ESQ®



#### ESQ Key Product Features:

- 800 lb. static load rating.
- Wide range of sizes to meet various applications.
- Desk and counter high frames for creating work stations.
- Three EIA panel widths - 19", 24" and 30."
- Ships fully assembled in 2 weeks.
- Available in the Instant Emcors Quick Ship Program.



### G-Series®



#### G-Series Key Product Features:

- 2000 lb. static load rating.
- Multi-vendor server enclosure
- Wide range of sizes to meet various applications.
- Two EIA panel widths - 19" and 24."
- Ships fully assembled in 2 weeks.

### 10 Series®



#### 10 Series Key Product Features:

- 3500 lb. static load rating.
- Wide range of sizes to meet various applications.
- Desk and counter high frames for creating work stations.
- Two EIA panel widths - 19" and 24."
- Ships fully assembled in 2 weeks.
- Available in the Instant Emcors Quick Ship Program.



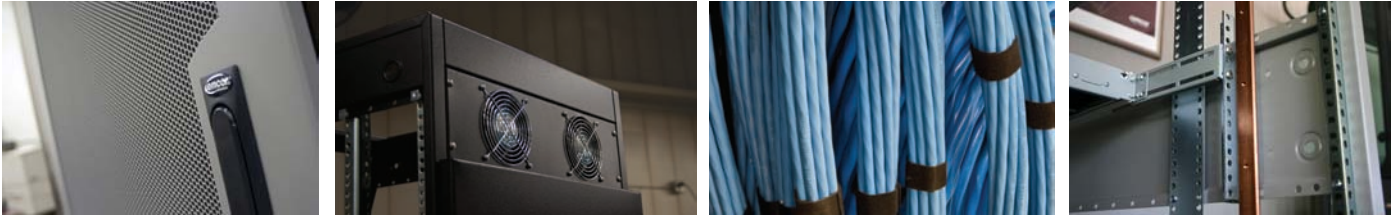

**Our Enclosures Feature:**

- Adjustable depth mounting rails that support a wide range of equipment.
- Independent, removable side, top panel, bottom panel and doors.
- Optional thermal management accessories to control airflow.
- A variety of cable management and power options.
- Multi-vendor server enclosure.
- Various door styles to match airflow requirements.
- Locking side panels and doors for equipment security.

**Common Modifications:**

- Strut re-locations.
- Holes and cut-outs.
- Ground studs.
- Pre-assembly or pre-wiring.
- Paint / decals.
- Service panels.
- Shock & vibration / IBC / seismic / NEMA.

**Modifications to the Overall Foot-print**

The gray area on charts below show the typical ranges to which each product line can be modified in terms of usable height, depth and width. Standard\* sizes are indicated within the gray area.

**ESQ**

U's	1U	3U	5U	7U	9U	11U	13U	15U	17U	19U	21U	23U	25U	27U	29U	31U	33U	35U	37U	39U	41U	43U	45U	47U	49U
Inches	1.75	5.25	8.75	12.25	15.75	19.25	22.75	26.25	29.75	33.25	36.75	40.25	43.75	47.25	50.75	54.25	57.75	61.25	64.75	68.25	71.75	75.25	78.75	82.25	85.75
Usable Height					6U	10U	12U	16U	20U	25U	30U	35U	40U	45U											
Overall Depth						18.500	22.000	25.500	30.750																
Overall Width							21.062	26.062	32.062																

\*Modifications to the standard foot-print may affect static load ratings, center of gravity and other performance.

**G-Series**

U's	1U	3U	5U	7U	9U	11U	13U	15U	17U	19U	21U	23U	25U	27U	29U	31U	33U	35U	37U	39U	41U	43U	45U	47U	49U
Inches	1.75	5.25	8.75	12.25	15.75	19.25	22.75	26.25	29.75	33.25	36.75	40.25	43.75	47.25	50.75	54.25	57.75	61.25	64.75	68.25	71.75	75.25	78.75	82.25	85.75
Usable Height																30U	35U	40U	42U	45U					
Overall Depth								26.312	31.562	36.875	42.125														
Overall Width								21.062	26.062																

\*Modifications to the standard foot-print may affect static load ratings, center of gravity and other performance.

**10 Series**

U's	1U	3U	5U	7U	9U	11U	13U	15U	17U	19U	21U	23U	25U	27U	29U	31U	33U	35U	37U	39U	41U	43U	45U	47U	49U
Inches	1.75	5.25	8.75	12.25	15.75	19.25	22.75	26.25	29.75	33.25	36.75	40.25	43.75	47.25	50.75	54.25	57.75	61.25	64.75	68.25	71.75	75.25	78.75	82.25	85.75
Usable Height								15U	19U	20U	23U	28U	30U	35U	36U	40U	45U	48U							
Overall Depth								26.312	31.562	36.875	42.125	47.375													
Overall Width								22.562	27.562																

to 54U

\*Modifications to the standard foot-print may affect static load ratings, center of gravity and other performance.



CAD files and BOM's are available on our website.

### Sample Configurations

The following pages show sample configurations made up of the following frame components. The number of standard options for each type of frame and the associated product line is listed below. Visit our website to download CAD files and complete BOMs.

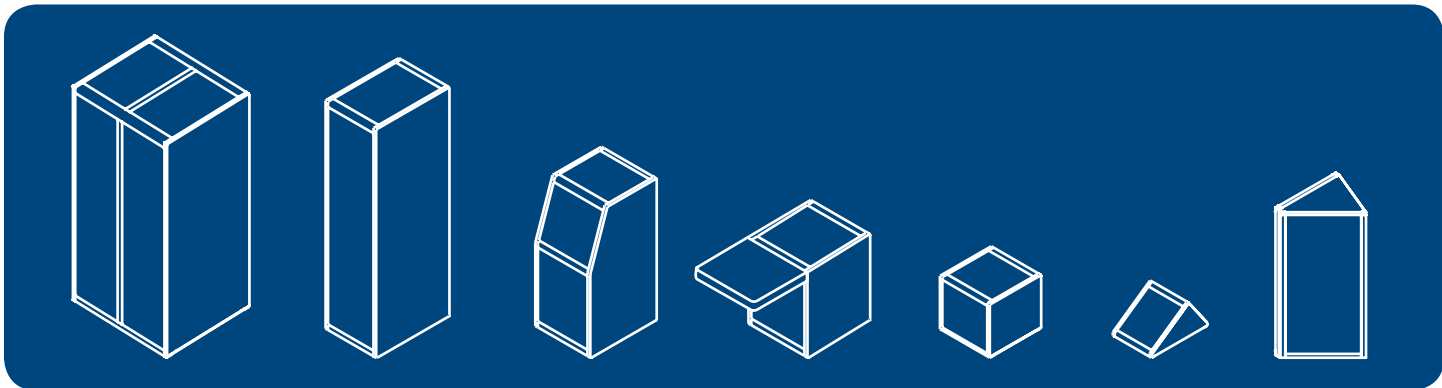

Dual-Bay	Vertical	Slope Front	Work Surface	Instrument	Turret	Wedge
ESQ N/A	ESQ 79 Options	ESQ 18 Options	ESQ 22 Options	ESQ 24 Options	ESQ 42 Options	ESQ 66 Options
G-Series 20 Options	G-Series 40 Options	G-Series N/A	G-Series N/A	G-Series N/A	G-Series N/A	G-Series N/A
10 Series N/A	10 Series 78 Options	10 Series 8 Options	10 Series 20 Options	10 Series N/A	10 Series 12 Options	10 Series 68 Options

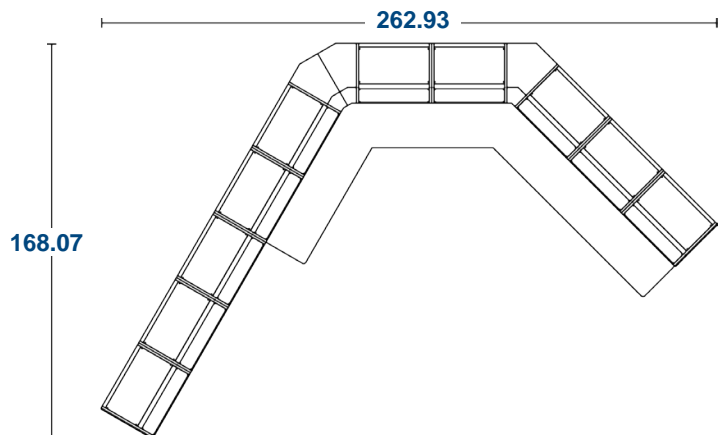
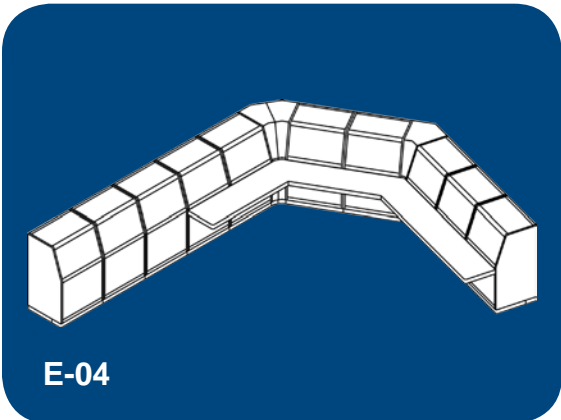
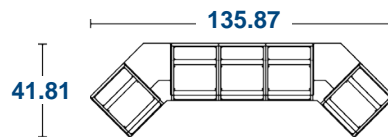
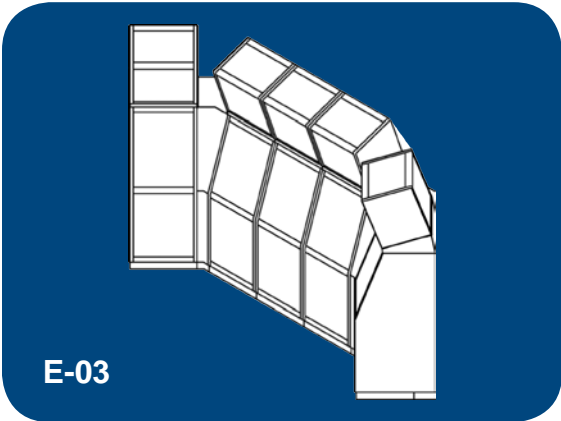
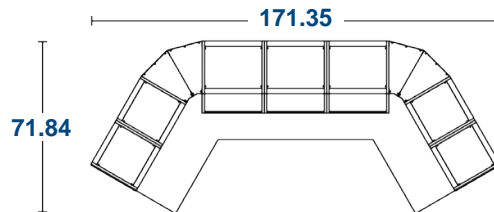
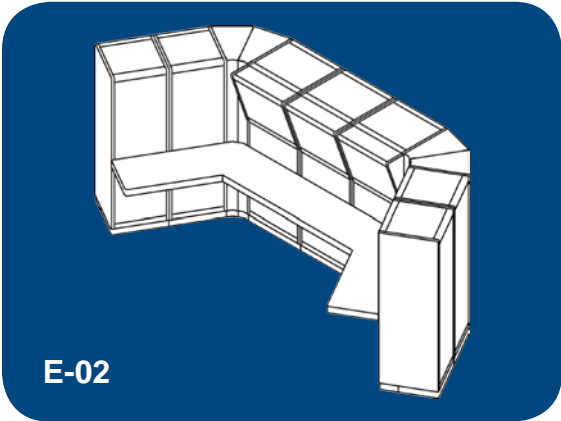
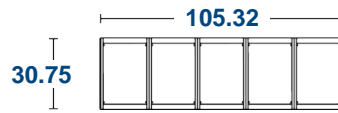
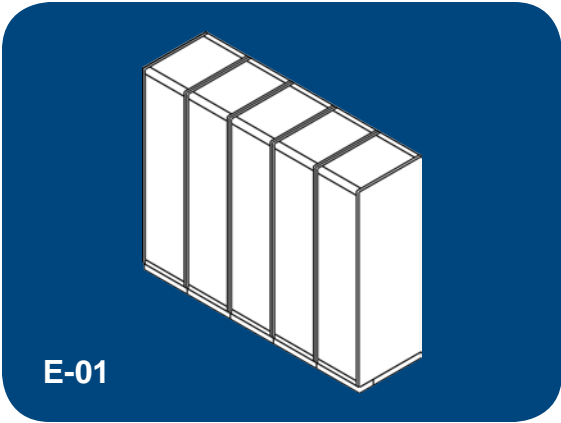

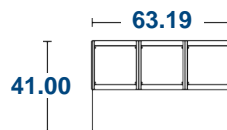
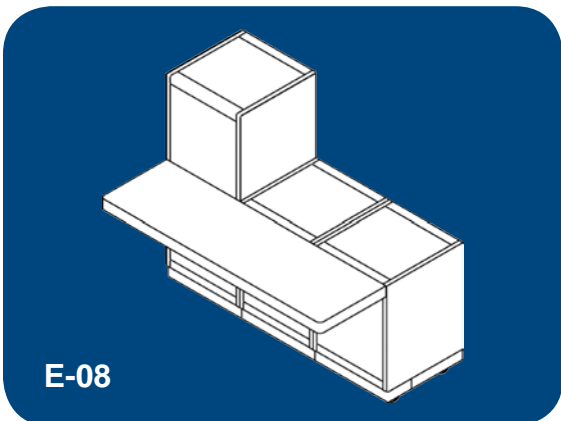
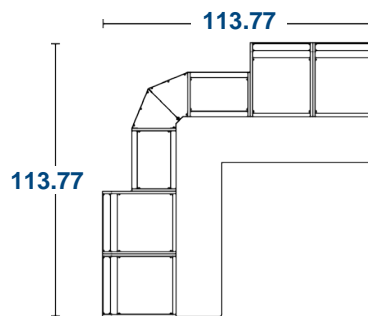
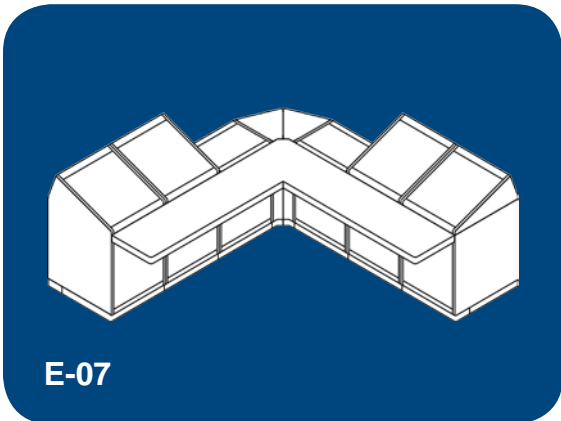
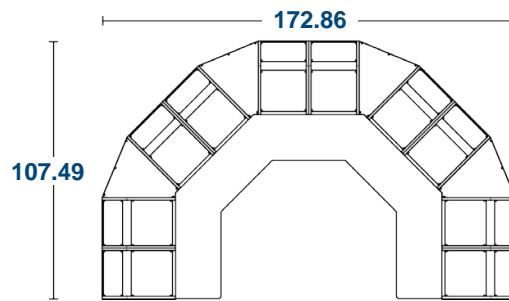
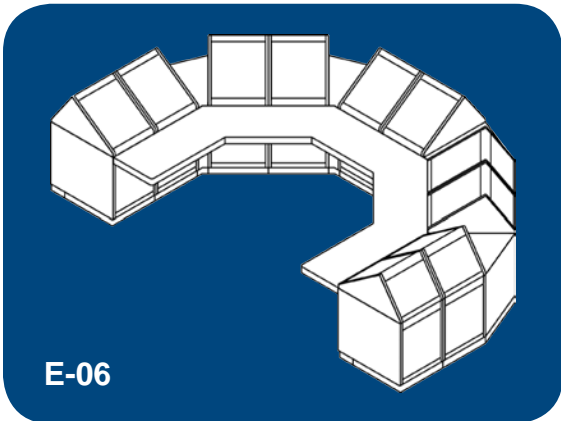
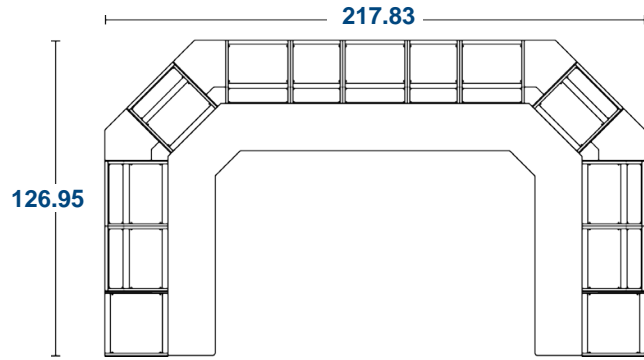
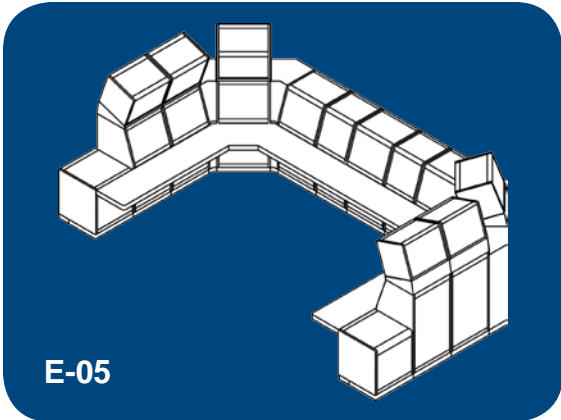

# G-Series Idea Guide

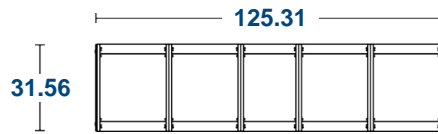
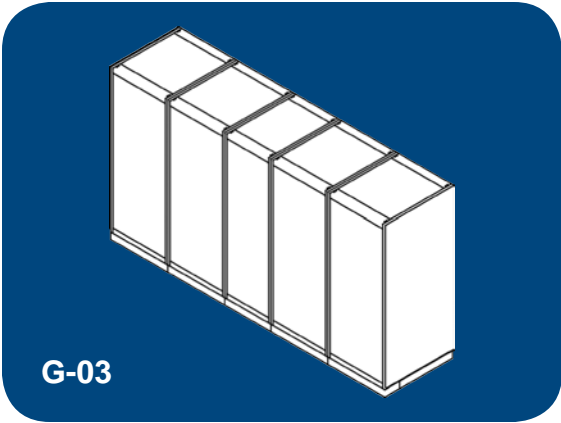
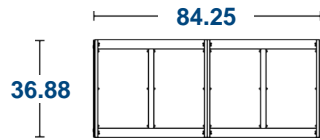
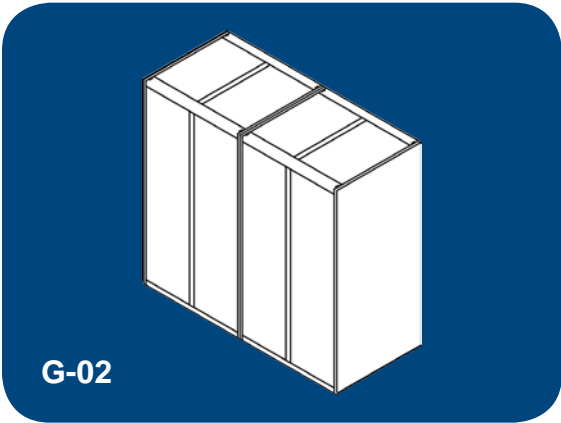
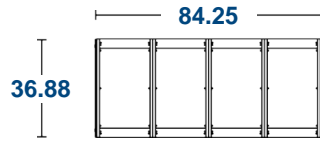
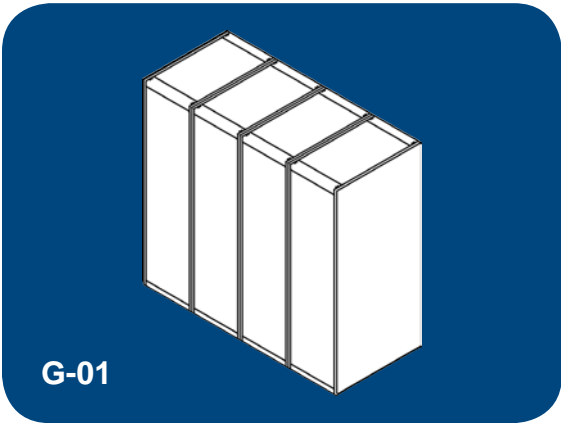



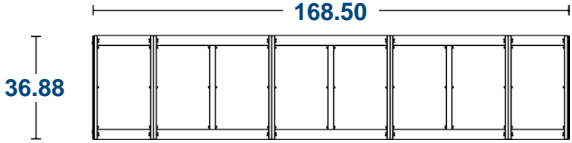
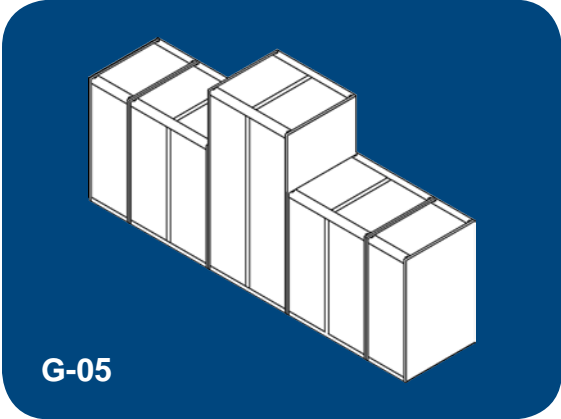
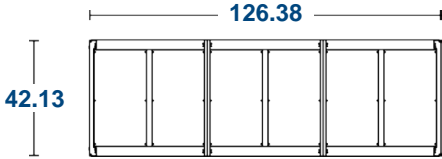
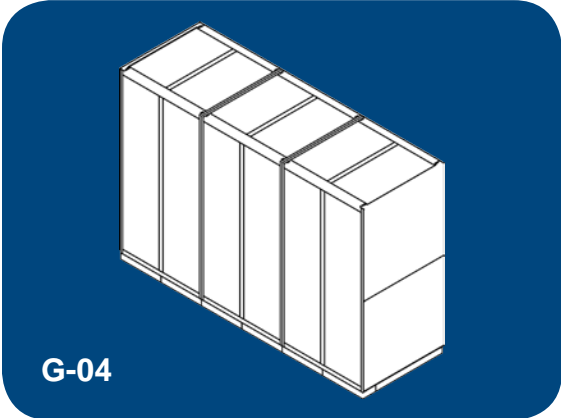

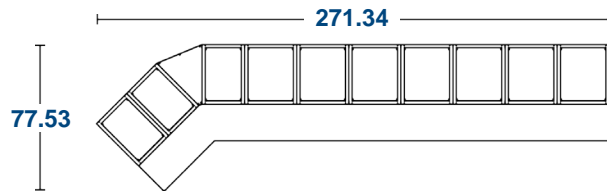
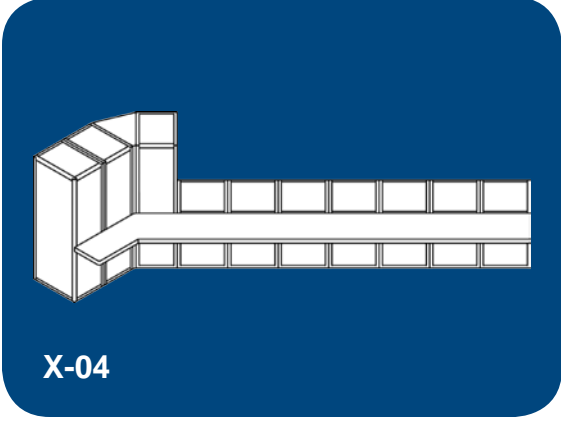
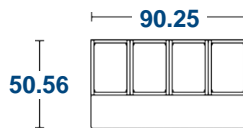
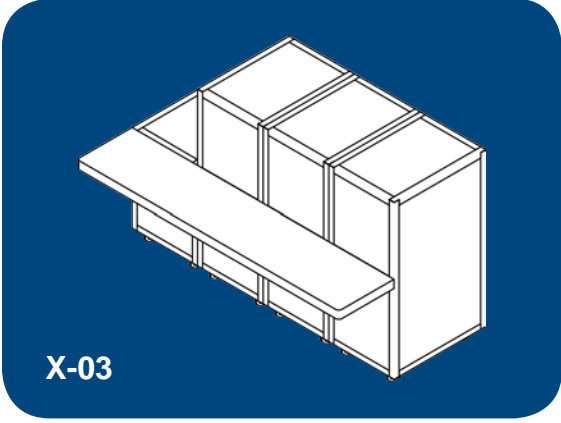
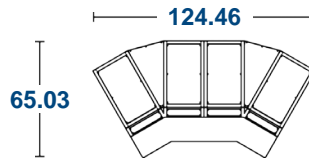
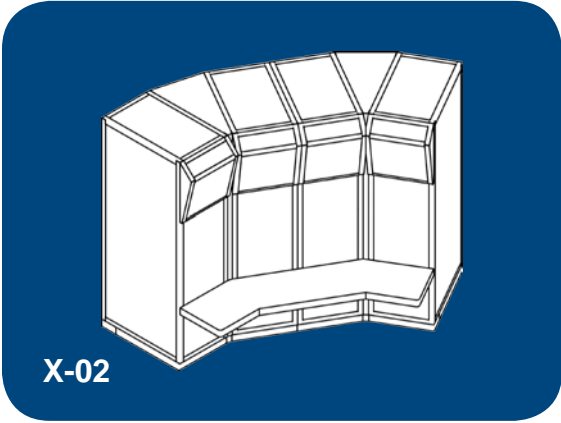
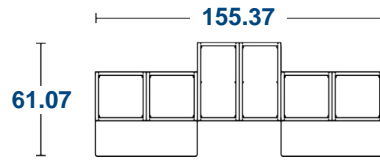
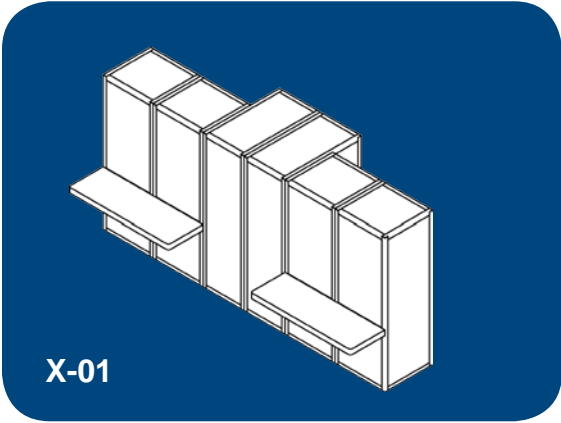

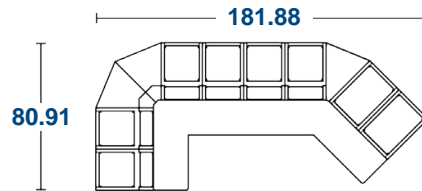
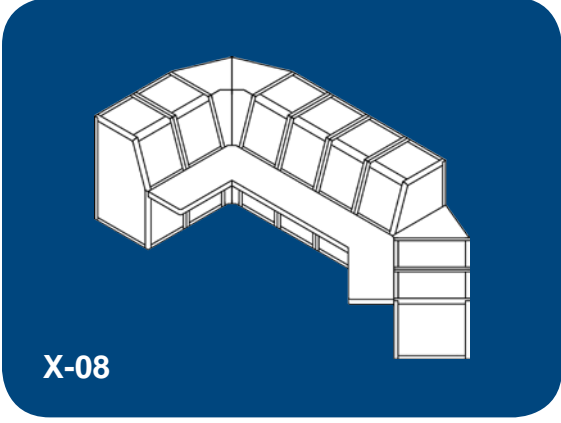
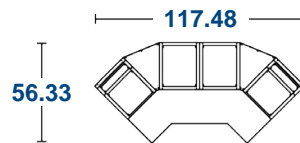
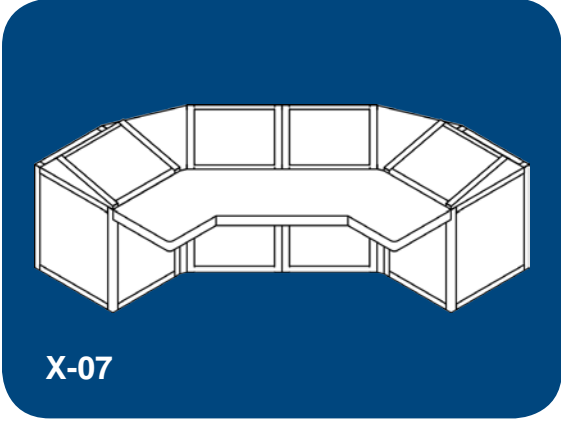
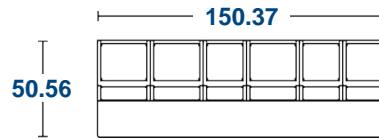
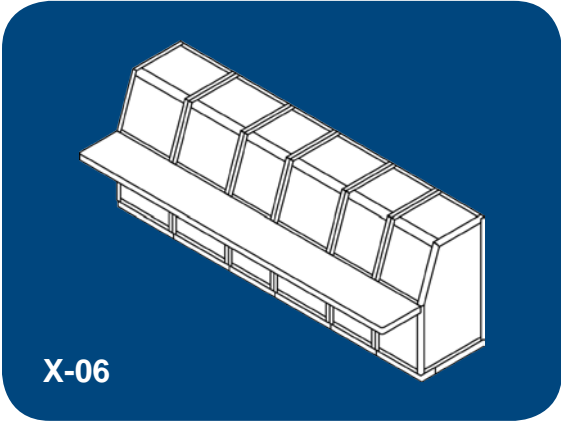
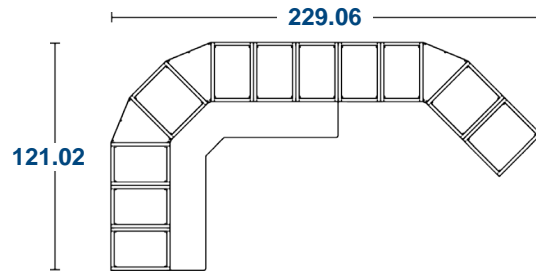
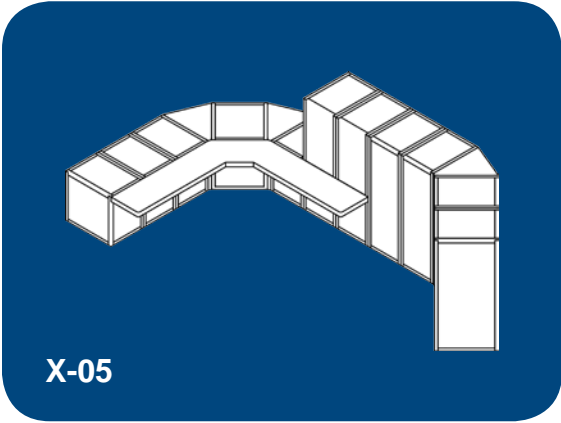

# Options and Accessories

## Paint/Finish

Our enclosures are finished in textured powder paint. Powder coating provides a durable high-quality finish. Select from one of nine proprietary color options. If needed, we offer air dry touch-up paint in three convenient sizes.

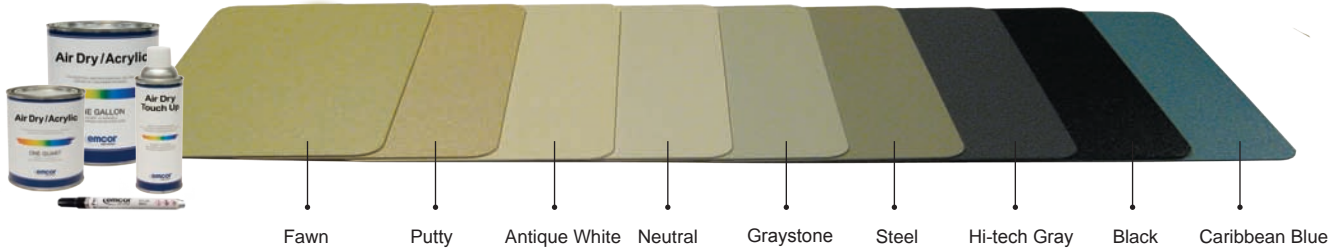

## Door Options

The following door options are available. The doors can be used on the front or rear of the cabinet. Select the type and style combination that best fits your functionality needs; whether it be visibility, air flow management, or simply aesthetics.

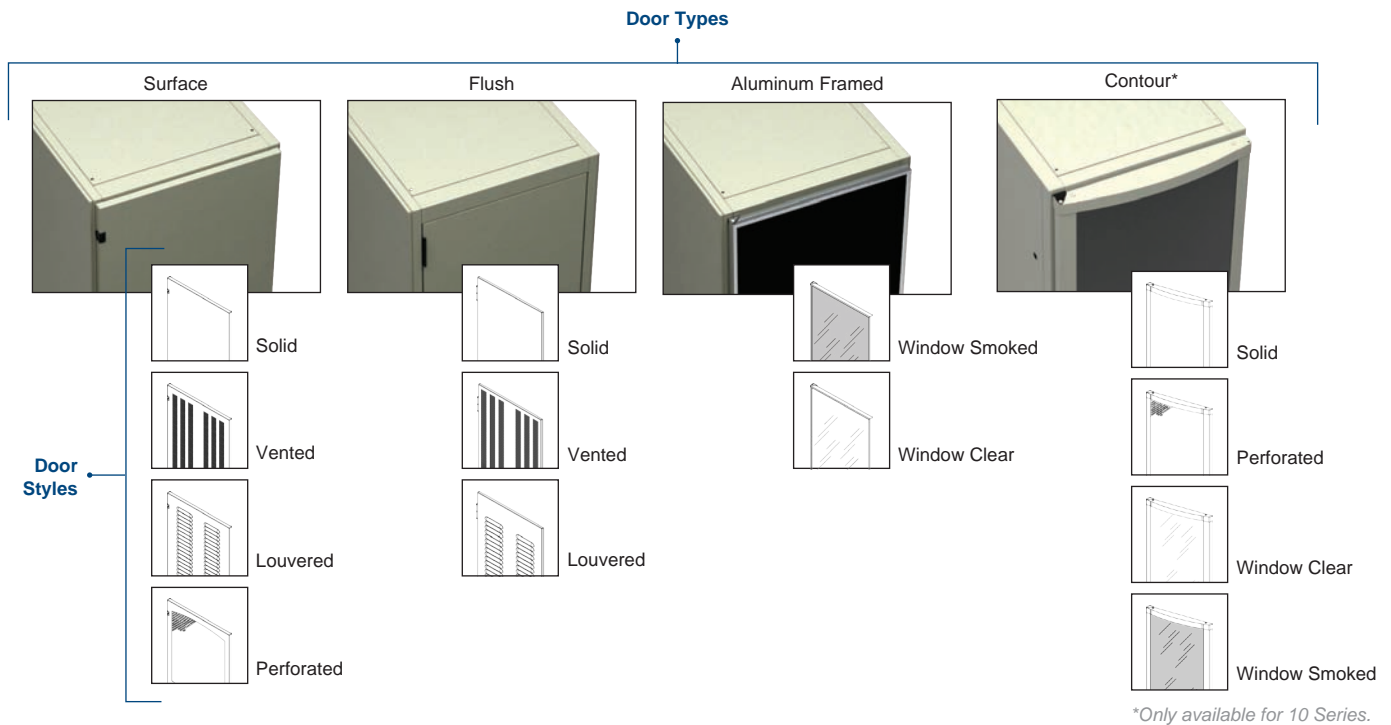

## Panels

Available in multiple styles, filler panels close off all, or portions of, the top, front, rear, and slope opening areas of the frame. Most styles available in 1U-45U heights and in 1U increments.

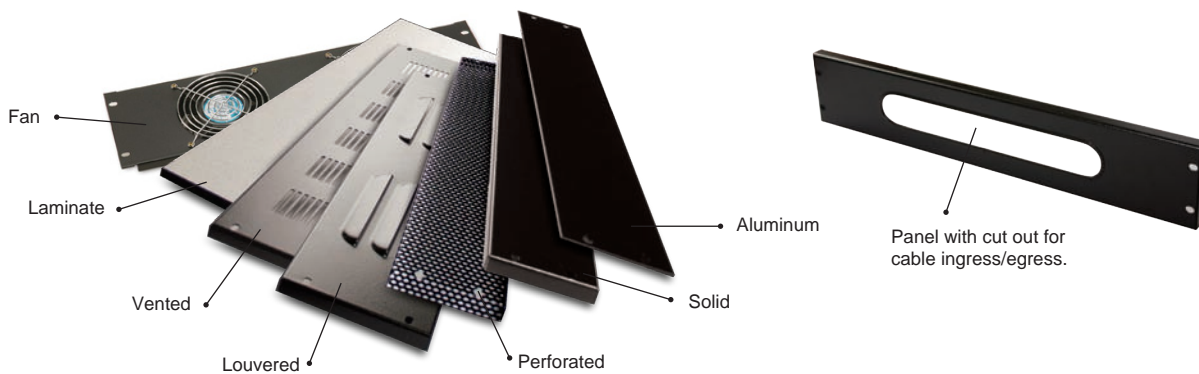

## Power

Crenlo offers one of the largest selection of enclosure power distribution units (PDUs) available on the market. This complete suite of power products is designed specifically to help IT professionals meet their rapidly escalating power requirements.

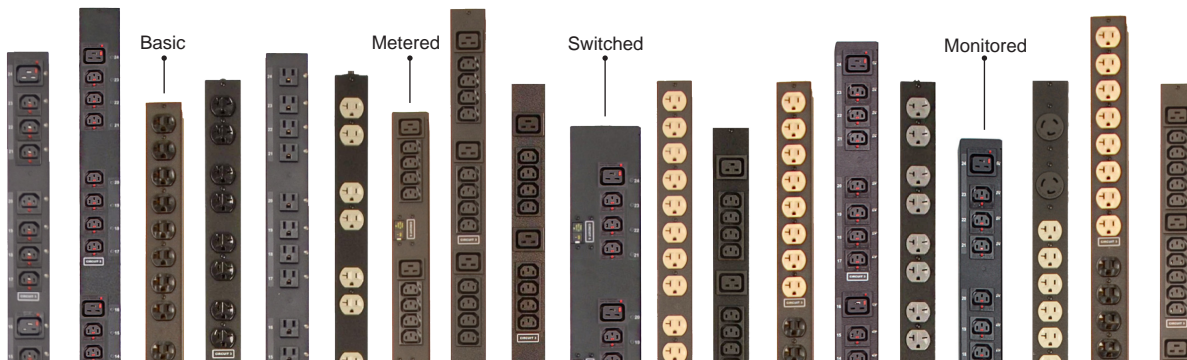

## Cable Management

Cabinets house more equipment today than ever before. This rise in equipment densities has increased the need for organized cable management. Poor cable management can not only lead to damaged cables or increased time to add or change out cables, but can block critical airflow or access. We offer the proper cable management options to meet varying needs.

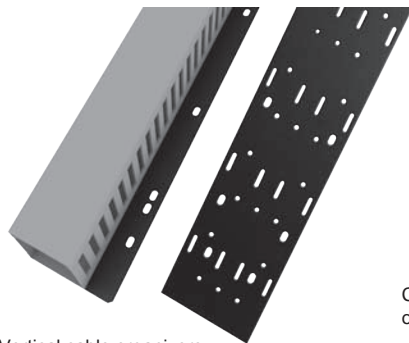

Vertical cable organizers and lacing panels.



Cable ties, Velcro and other accessories.

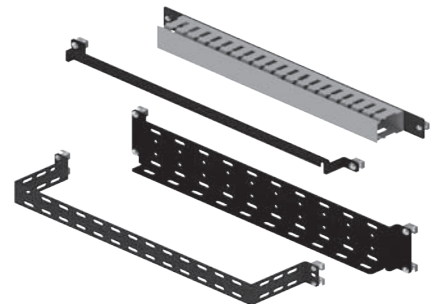

Horizontal cable organizers and lacing panels.

## Work Surface Styles and Laminate Options

Select from the following work surface styles and laminate options. Unique surfaces such as static dissipative can be accommodated.

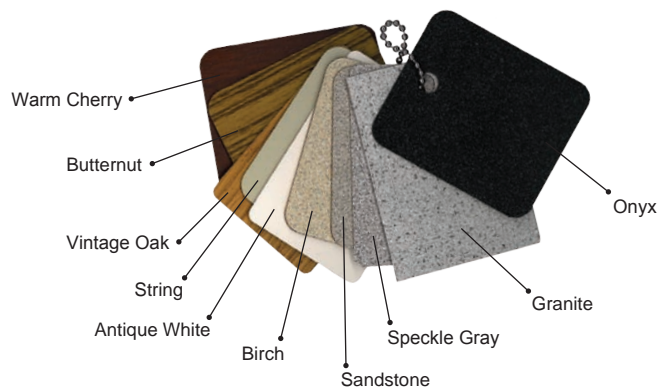
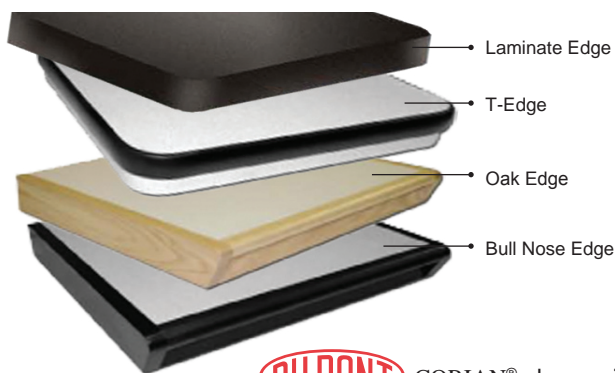

**DUPONT** CORIAN® also available.

# Options and Accessories

## Accessories

We offer a variety of additional accessories to tailor an enclosure to specific application needs. Most of the items listed below can be used in either the ESQ, G-Series or 10 Series product lines. For a complete list of available accessories visit our website.

### Shelves

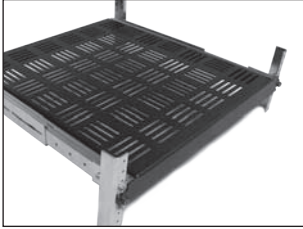

Chassis Guides (200 lbs.)  
Monitor Shelf (50 lbs.)  
Fixed Shelf (125-200 lbs.)  
Sliding Shelf (90-112 lbs.)

### Air Flow Management

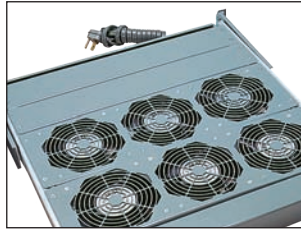

Pagoda Style Venting (Natural Convection)  
Single Fan Panels (550 CFM)  
Dual Fan Panels (204 CFM)  
Fan Trays (290-586 CFM)  
Blowers (125-500 CFM)  
Pagoda Impellers (1040 CFM)

### Drawers



Drawer (2U-8U) (90 lbs.)  
Drawer with Lid (90 lbs.)  
Keyboard Tray

### Power

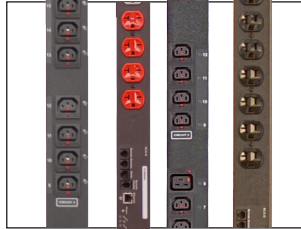

Basic, Metered, Monitored, Switched  
15-60 Amp  
120-208 Volt  
Vertical and Horizontal Orientations  
NEMA / IEC / CA Style Plugs and Receptacles  
Environmental Control (Temp, Humidity, Dew Point)

### Grounding



Bus Plate (14 Grounding Holes)  
Bus Bar (12U-45U)  
Ground Studs

### Cable Management

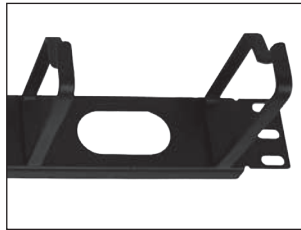

Vertical Lacing Panels and Cable Organizers  
Horizontal Lacing Panels and Cable Organizers  
Overhead Cable Trays  
Cable Ingress/Egress Panels  
Velcro and Other Cable Ties

### Casters



75# Soft Rubber  
75# Polypropylene  
180# Hard Rubber  
200# Soft Rubber (LK option)  
375# Hard Rubber (LK option)

### Lighting



Rack-mount or Panel-mount Style  
LED and Halogen Bulbs  
12" and 18" Gooseneck Lengths  
Bases for conversion to task lighting



**Our Commitment**

Crenlo's objective is to define our customer's quality requirements, and to produce products and services that meet or exceed those expectations. Crenlo is committed to continuous improvement through education, process advancements and problem prevention.

# Emcor Product Portfolio

## Emcor® Enclosures

This standard product lineup includes a range of vertical racks and cabinets, which can be configured or modified with numerous accessories and sizes to meet your diverse needs.



ESQ®



G-Series®



10 Series®



Data Center

## Emcor® Consoles

This standard product lineup includes a range of monitoring and control consoles, which can be configured and modified in countless modular configurations.



FP1



FP2



ESQ®



Air Traffic Control

## Custom Products

For those needs that fall outside of Crenlo's standard Emcor products, we can build completely custom solutions to meet the needs of any customer.



Inverter Enclosure



Kiosk



NEMA



Package Drop Box